

NEHRU COLLEGE OF ENGINEERING AND RESEARCH CENTRE

(Accredited by NAAC, Approved by AICTE New Delhi, Affiliated to APJKTU)

Pampady, Thiruvilwamala(PO), Thrissur(DT), Kerala 680 588

DEPARTMENT OF MECHANICAL ENGINEERING



LAB WORK BOOK



ESL130 ELECTRONICS WORKSHOP

VISION OF THE INSTITUTION

To mould true citizens who are millennium leaders and catalysts of change through excellence in education.

MISSION OF THE INSTITUTION

NCERC is committed to transform itself into a center of excellence in Learning and Research in Engineering and Frontier Technology and to impart quality education to mould technically competent citizens with moral integrity, social commitment and ethical values.

We intend to facilitate our students to assimilate the latest technological know-how and to imbibe discipline, culture and spiritually, and to mould them in to technological giants, dedicated research scientists and intellectual leaders of the country who can spread the beams of light and happiness among the poor and the underprivileged.

ABOUT DEPARTMENT

- ◆ Established in: 2002

- ◆ Course offered : B.Tech in Mechanical Engineering
- ◆ Approved by AICTE New Delhi and Accredited by NAAC
- ◆ Affiliated to the University of Dr. A P J Abdul Kalam Technological University.

DEPARTMENT VISION

Producing internationally competitive Mechanical Engineers with social responsibility & sustainable employability through viable strategies as well as competent exposure oriented quality education.

DEPARTMENT MISSION

1. Imparting high impact education by providing conducive teaching learning environment.
2. Fostering effective modes of continuous learning process with moral & ethical values.
3. Enhancing leadership qualities with social commitment, professional attitude, unity, team spirit & communication skill.
4. Introducing the present scenario in research & development through collaborative efforts blended with industry & institution.

PROGRAMME EDUCATIONAL OBJECTIVES

- PEO1:** Graduates shall have strong practical & technical exposures in the field of Mechanical Engineering & will contribute to the society through innovation & enterprise.
- PEO2:** Graduates will have the demonstrated ability to analyze, formulate & solve design engineering / thermal engineering / materials & manufacturing / design issues & real life problems.
- PEO3:** Graduates will be capable of pursuing Mechanical Engineering profession with good communication skills, leadership qualities, team spirit & communication skills.
- PEO4:** Graduates will sustain an appetite for continuous learning by pursuing higher education & research in the allied areas of technology.

Course Outcomes: After the completion of the course the student will be able to

| | |
|------|---|
| CO 1 | Demonstrate safety measures against electric shocks. |
| CO 2 | Identify the tools used for electrical wiring, electrical accessories, wires, cables, batteries and standard symbols. |
| CO 3 | Develop the connection diagram, identify the suitable accessories and materials necessary for wiring simple lighting circuits for domestic buildings. |
| CO 4 | Identify and test various electronic components |
| CO 5 | Draw circuit schematics with EDA tools |
| CO 6 | Assemble and test electronic circuits on boards |
| CO 7 | Work in a team with good interpersonal skills |

Mapping of course outcomes with program outcomes

| | PO 1 | PO 2 | PO 3 | PO 4 | PO 5 | PO 6 | PO 7 | PO 8 | PO 9 | PO 10 | PO 11 | PO 12 |
|------|------|------|------|------|------|------|------|------|------|-------|-------|-------|
| CO 1 | - | - | - | - | - | 3 | - | - | - | - | - | 1 |
| CO 2 | 2 | - | - | - | - | - | - | - | - | 1 | - | - |
| CO 3 | 2 | - | - | 1 | - | 1 | - | 1 | 2 | 2 | - | 2 |
| CO 4 | 3 | - | - | - | - | - | - | - | - | - | - | 2 |
| CO 5 | 3 | - | - | - | 2 | - | - | - | - | - | - | 2 |
| CO 6 | 3 | - | - | - | 2 | - | - | - | - | - | - | 1 |
| CO 7 | - | - | - | - | - | - | - | - | 3 | 2 | - | 2 |

SYLLABUS

| | | | | | | | |
|---------|-----------------------------------|----------|---|---|---|--------|----------------------|
| ESL 130 | ELECTRICAL & ELECTRONICS WORKSHOP | CATEGORY | L | T | P | CREDIT | YEAR OF INTRODUCTION |
| | | ESC | 0 | 0 | 2 | 1 | 2019 |

Preamble: Electrical Workshop is intended to impart skills to plan and carry out simple electrical wiring. It is essential for the practicing engineers to identify the basic practices and safety measures in electrical wiring.

Prerequisite: NIL

Course Outcomes: After the completion of the course the student will be able to

| | |
|------|---|
| CO 1 | Demonstrate safety measures against electric shocks. |
| CO 2 | Identify the tools used for electrical wiring, electrical accessories, wires, cables, batteries and standard symbols. |
| CO 3 | Develop the connection diagram, identify the suitable accessories and materials necessary for wiring simple lighting circuits for domestic buildings. |
| CO 4 | Identify and test various electronic components |
| CO 5 | Draw circuit schematics with EDA tools |
| CO 6 | Assemble and test electronic circuits on boards |
| CO 7 | Work in a team with good interpersonal skills |

Mapping of course outcomes with program outcomes

| | PO 1 | PO 2 | PO 3 | PO 4 | PO 5 | PO 6 | PO 7 | PO 8 | PO 9 | PO 10 | PO 11 | PO 12 |
|------|------|------|------|------|------|------|------|------|------|-------|-------|-------|
| CO 1 | - | - | - | - | - | 3 | - | - | - | - | - | 1 |
| CO 2 | 2 | - | - | - | - | - | - | - | - | 1 | - | - |
| CO 3 | 2 | - | - | 1 | - | 1 | - | 1 | 2 | 2 | - | 2 |
| CO 4 | 3 | - | - | - | - | - | - | - | - | - | - | 2 |
| CO 5 | 3 | - | - | - | 2 | - | - | - | - | - | - | 2 |
| CO 6 | 3 | - | - | - | 2 | - | - | - | - | - | - | 1 |
| CO 7 | - | - | - | - | - | - | - | - | 3 | 2 | - | 2 |

Mark distribution

| Total Marks | CIE | ESE | ESE Duration(Internal) |
|-------------|-----|-----|------------------------|
| 100 | 100 | - | 1 hour |

DOWNLOADED FROM KYUASSIST.IN

Continuous Internal Evaluation Pattern:

| | |
|--|------------|
| Attendance | : 20 marks |
| Class work/ Assessment/Viva-voce | : 50 marks |
| End semester examination (Internally by college) | : 30 marks |

End Semester Examination Pattern: Written Objective Examination of one hour

Syllabus

PART 1

ELECTRICAL

List of Exercises / Experiments

1. a)Familiarization/Identification of electronic components with specification (Functionality, type, size, colour coding, package, symbol, cost etc. [Active, Passive, Electrical, Electronic, Electro-mechanical, Wires, Cables, Connectors, Fuses, Switches, Relays, Crystals, Displays, Fasteners, Heat sink etc.)
b) Identify different types of cables, wires, switches, fuses, fuse carriers, MCB, ELCB and MCCB with ratings.
2. Wiring of simple light circuit for controlling light/ fan point (PVC conduit wiring)
3. Wiring of light/fan circuit using Two way switches . (Staircase wiring)
4. Wiring of Fluorescent lamps and light sockets (6A) with a power circuit for controlling power device. (16A socket)
5. Wiring of power distribution arrangement using single phase MCB distribution board with ELCB, main switch and Energy meter.
6. a)Identify different types of batteries with their specifications.
b)Demonstrate the Pipe and Plate Earthing Schemes using Charts/Site Visit.

PART II

ELECTRONICS

List of Exercises / Experiments (Minimum of 7 mandatory)

1. Familiarization/Identification of electronic components with specification (Functionality, type, size, colour coding, package, symbol, cost etc. [Active, Passive,

DOWNLOADED FROM KTUASSIST.IN

Electrical, Electronic, Electro-mechanical, Wires, Cables, Connectors, Fuses, Switches, Relays, Crystals, Displays, Fasteners, Heat sink etc.)

2. Drawing of electronic circuit diagrams using BIS/IEEE symbols and introduction to EDA tools (such as Dia or Xcircuit), Interpret data sheets of discrete components and IC's, Estimation and costing.
3. Familiarization/Application of testing instruments and commonly used tools. [Multimeter, Function generator, Power supply, DSO etc.] [Soldering iron, Desoldering pump, Pliers, Cutters, Wire strippers, Screw drivers, Tweezers, Crimping tool, Hot air soldering and de-soldering station etc.]
4. Testing of electronic components [Resistor, Capacitor, Diode, Transistor and JFET using multimeter.]
5. Inter-connection methods and soldering practice. [Bread board, Wrapping, Crimping, Soldering - types - selection of materials and safety precautions, soldering practice in connectors and general purpose PCB, Crimping.]
6. Printed circuit boards (PCB) [Types, Single sided, Double sided, PTH, Processing methods, Design and fabrication of a single sided PCB for a simple circuit with manual etching (Ferric chloride) and drilling.]
7. Assembling of electronic circuits using SMT (Surface Mount Technology) stations.
8. Assembling of electronic circuit/system on general purpose PCB, test and show the functioning (**Any Two circuits**).
 1. Fixed voltage power supply with transformer, rectifier diode, capacitor filter, zener/IC regulator.
 2. Square wave generation using IC 555 timer in IC base.
 3. Sine wave generation using IC 741 OP-AMP in IC base.
 4. RC coupled amplifier with transistor BC107.

DOWNLOADED FROM KTUASSIST.IN

PREPARATION FOR THE LABORATORY SESSION
GENERAL INSTRUCTIONS TO STUDENTS

1. Read carefully and understand the description of the experiment in the lab manual. You may go to the lab at an earlier date to look at the experimental facility and understand it better. Consult the appropriate references to be completely familiar with the concepts and hardware.
2. Make sure that your observation for previous week experiment is evaluated by the faculty member and you have transferred all the contents to your record before entering to the lab/workshop.
3. At the beginning of the class, if the faculty or the instructor finds that a student is not adequately prepared, they will be marked as absent and not be allowed to perform the experiment.
4. Bring necessary material needed (writing materials, graphs, calculators, etc.) to perform the required preliminary analysis. It is a good idea to do sample calculations and as much of the analysis as possible during the session. Faculty help will be available. Errors in the procedure may thus be easily detected and rectified.
5. Please actively participate in class and don't hesitate to ask questions. Please utilize the teaching assistants fully. To encourage you to be prepared and to read the lab manual before coming to the laboratory, unannounced questions may be asked at any time during the lab.
6. Carelessness in personal conduct or in handling equipment may result in serious injury to the individual or the equipment. Do not run near moving machinery/equipment. Always be on the alert for strange sounds. Guard against entangling clothes in moving parts of machinery.
7. Students must follow the proper dress code inside the laboratory. To protect clothing from dirt, wear a lab coat. Long hair should be tied back. Shoes covering the whole foot will have to be worn.
8. In performing the experiments, please proceed carefully to minimize any water spills, especially on the electric circuits and wire.
9. Maintain silence, order and discipline inside the lab. Don't use cell phones inside the laboratory.

10. Any injury no matter how small must be reported to the instructor immediately.

11. Check with faculty members one week before the experiment to make sure that you have the handout for that experiment and all the apparatus.

AFTER THE LABORATORY SESSION

1. Clean up your work area.
2. Check with the technician before you leave.
3. Make sure you understand what kind of report is to be prepared and due submission of record is next lab class.
4. Do sample calculations and some preliminary work to verify that the experiment was successful

MAKE-UPS AND LATE WORK

Students must participate in all laboratory exercises as scheduled. They must obtain permission from the faculty member for absence, which would be granted only under justifiable circumstances. In such an event, a student must make arrangements for a make-up laboratory, which will be scheduled when the time is available after completing one cycle. Late submission will be awarded less mark for record and internals and zero in worst cases.

LABORATORY POLICIES

1. Food, beverages & mobile phones are not allowed in the laboratory at any time.
2. Do not sit or place anything on instrument benches.
3. Organizing laboratory experiments requires the help of laboratory technicians and staff. Be punctual.

SAFETY PRECAUTIONS

1. Always wear tight clothes
2. Never walk barefooted inside the Work Shop. Prefer to use Rubber soled shoes; closed shoe is recommended
3. Never try to operate any machine unless you know how to operate it.
4. Never touch moving parts.
5. Do not use defective tools.
6. Do not touch any live wire
7. In case of fire, disconnect the electric supply.
8. Those who have long hair should take precaution by dressing them properly.
9. Tools which are not being used should always be kept at their respective places.
10. Never carry an open sharp tool in the pocket.
11. Do not cut work piece by holding it in hand.
12. Never work in a place where there is no sufficient light.
13. Always keep in mind the position of fire extinguishers and first aid box.
14. The job should be properly fitted in the vice.
15. Use always the right tool for the right job.
16. Don't use file or spanner as a hammer.
17. Always try to learn things sincerely from the instructors concerned.
18. Always keep your mind on the job.
19. Make sure that your work is not affecting the work of fellow students in the work shop.
20. Shop floor must be kept clean, free from scarp, oil and grease.

EXPT NO: 1

DATE:

FAMILIARIZATION OF ELECTRONIC COMPONENTS**Aim:**

To familiarize various electronic components (passive and active components) used in electronics laboratory.

Components Required:

Various passive and active components.

Theory:

An electronic circuit consists of different electronic components. These electronic components are divided into:

- a) Passive components
- b) Active components

Passive components:

They are not capable of amplifying or processing an electric signal by themselves. Resistors, capacitors and inductors are examples. They conduct current in both directions.

1. RESISTORS:

They resist the flow of current through a circuit. Resistance is measured in ohms. They are characterized by resistance value, tolerance, power handling capacity, temperature coefficient etc. Resistors are of two types – fixed and variable resistors.

Resistors control the current and also act as voltage divider in the circuit

Fixed Resistors:

It has a fixed resistance value which cannot be adjusted. They are of the following types.

a) Carbon Composition resistors:-

It is the most common fixed low voltage resistor. These resistors are made by mixing carbon powder and insulating binders. The available resistance values are 1Ω to $10\text{ M}\Omega$ with power

rating $\frac{1}{8}\text{ W}$, $\frac{1}{4}\text{ W}$, $\frac{1}{2}\text{ W}$, 1 W and 2 W . It is used in general purpose electronic equipment and high frequency circuits.

b) Carbon Film Resistors:-

They are made of high grade ceramic core on which a thin resistive film of C is deposited and available in the range from 10Ω to $10\text{ M}\Omega$ values with power rating up to 2 W . They are used in amplifiers, AF circuits, in measuring instruments where close tolerances are required.



Symbol of resistor



Carbon Composition Resistors

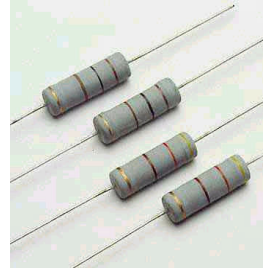

Carbon Film Resistors

c) Wire Wound Resistors:-

It is made by tightly winding a known length of the wire around a ceramic substrate and the other end of the wire is soldered to cap on the other end. The wire used are nichrome, constantan etc. The resistance values range from 1Ω to 100Ω with power rating of carbon track potentiometer is up to 2W. For high power applications wire wound pots are used.



Wire wound resistors

d) Metal film resistors

They have high stability and their temperature coefficient of resistance can be accurately controlled. They are of two types 1) thin film 2) thick film. Thin film resistors are available from 10Ω to $1k\Omega$ with typical 5W power rating. In the latter type thickness of metal film is more.

Variable resistors

These are resistors whose resistance values can be changed between zero and a particular value. They are used to control various types of circuits in receivers such as volume, brightness etc. and in electrical circuits for fine variation of voltage and current.

They are of two types linear and non-linear.

a) Potentiometer:- it is a three terminal variable resistor used for volume, brightness controls in radio and TV receivers. These are available in the following values: 470Ω , 1k, 2.2k, 4.7k, 10 k, 22k, 47k and 100 k. Power rating of carbon track potentiometer is up to 2W. For high power applications wire wound pots are used.

b) Preset:-

These are potentiometers used for adjusting resistance value to the correct required value. These are of two types-single turn and multi turn. It is used for low voltage cases, used for presetting the line frequency and frame frequency in a TV receiver.



Potentiometer



Preset

c) Light Dependent Resistor:

Its resistance varies with incident light intensity. The lower the current of light falling on the surface, higher will be the value of resistance of material. They are widely used in light meters etc.



Light dependant resistor

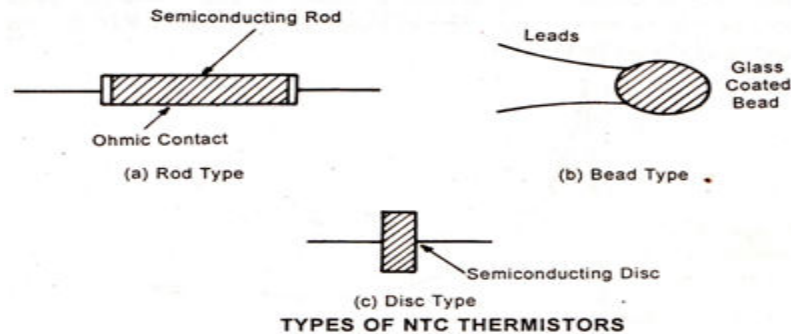

2. CAPACITORS

It is used to store electrical energy and release them whenever desired. It offers low impedance to a.c and high impedance to d.c. It is of two types: Fixed and variable.

Fixed capacitors

It has a fixed capacitance value and is classified according to the dielectric used.

a) Ceramic capacitors:

A ceramic disc is coated on two sides with a metal. These coating acts as two plates. Tinned wire leads are attached to each plate. The entire unit is coated with plastic. The capacitance range is 3 pF to 2 μF with voltage rating 3 to 6000V. It is used in RF amplifiers.

b) Electrolytic capacitor:

It consists of Al foil electrodes with Al₂O₃ film covering one side. Al plates are electrodes. It is used for bypass and decoupling process. It is used also as power supply filter. The capacitance range is 1 μF to 1000 μF with voltage range up to 400V.

c) Paper Capacitor:

It consists of two metal foils separated by strips of paper. The paper is impregnated with a dielectric material. The foil and paper are rolled in the form of cylinder. The capacitance range is 0.0005μF with voltage rating up to 1000V. It is used for starting and running of motors.

d) Mica capacitors:-

It consists of a number of flat strips of foil separated by mica strips. Capacitance vary from 5 pF to 0.2 μF. They are rated up to 500V with low leakage current.



Disc type ceramic capacitor



Tubular shaped For high voltage purpose
Electrolytic capacitors



Paper capacitors

Mica capacitors

Variable capacitors:-

In some circuits like tuning circuit, it is desirable to be able to change the value of capacitance readily. This is done by variable capacitor.

a) Gang capacitor:-

The dielectric for this capacitor is air. By rotating the shaft at one end, we can change common area between movable and fixed set of plates. As area increases, capacitance increases. It can be double and single section capacitors. The capacitance range is 15 pF to 500pF with voltage rating up to 1000V. It is used in tuning transmitters and receivers.

b) Padder capacitor:-

It is an air trimmer with comparatively high value capacitance. It consists of two tiny aluminum cups, mounted concentrically. By turning the screw, the gap between the two cups can be varied to vary the capacitance. The capacitance range is 5pF to 600pF.

Numerical code:

In small value capacitors like mica capacitors, value of capacitor will be written in coded form.

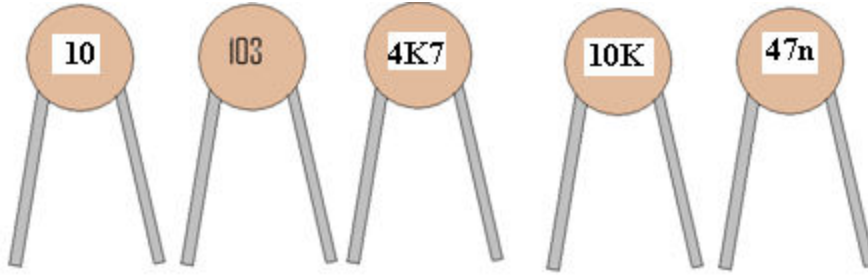

1. If the number written on the capacitor is greater than one, the value will be in pF. Otherwise, it will be in μF . For example, 10 means 10pF and 0.1 means 0.1 μF .
2. If there are three digits in the number, the third digit indicates the number of zeroes to be put after two digits and the value will be in pF. 104 means 10,000pF.
3. If the letter K follows the digits, the value will be in KpF (kilo pico farads). 10K means 10KpF or 0.01 μF
4. If the letter is 'n' or 'M', the value will be that much nano farads or micro farads respectively. 47n means 47nF and 47M means 47 Micro Farads.
5. If the letters, 'n', 'M' or 'K' is marked between two numerals, the value of the capacitor can be obtained by putting a decimal in place of the letter and multiplying it by the factor nF, μF or KpF respectively. 4K7 means 4.7KPF and 2M2 means 2.2 μF .
6. If the letters k or M follows the three digit numbers, it implies the tolerance value 10% and 20% respectively.

3.INDUCTORS:

Inductor is a coil wound on a core of suitable material. They are energy storage elements. They oppose sudden change in flow of current in a circuit. They are of two types: Fixed and Variable.

Short wave Inductor:-

It is used in the short wave region. It is used in TV antenna coil. Short wave is the general designation of radio transmission with wave length between 10 and 200m.

TRANSFORMERS:-

It is a device which changes the voltage and current levels of a given signal, keeping the power level same. It transfers energy from one coil to another through magnetic flux leakage.

a) Intermediate Frequency Transformer (IFT)

It has two or more windings designed to pass a specific band of radio frequencies which result from heterodyning a local oscillator signal with a RF signal. The colours are usually white, yellow, and green. It is used in medium wave range in radio receiver.

b) Step down Transformer:

It is used to reduce the voltage level of the input ac signal to the desired value by adjusting the number of primary and secondary turns.

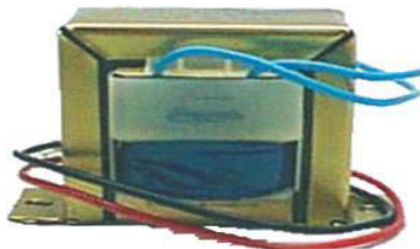

Step down Transformer

COLOUR CODING OF RESISTORS:-**Four Colour Band System**

The resistance values are colour coded for the carbon resistors since it is too small to print the value directly in figures. The first and second bands indicate the two significant digits, the third gives the number of zeros to follow. The fourth indicates the tolerance.

| Colour | Digit | Multiplier | Tolerance |
|-----------|-------|------------|-----------|
| Black | 0 | 10^0 | |
| Brown | 1 | 10^1 | |
| Red | 2 | 10^2 | |
| Orange | 3 | 10^3 | |
| Yellow | 4 | 10^4 | |
| Green | 5 | 10^5 | |
| Blue | 6 | 10^6 | |
| Violet | 7 | 10^7 | |
| Gray | 8 | 10^8 | |
| White | 9 | 10^9 | |
| Gold | - | 10^{-1} | ±5% |
| Silver | - | 10^{-2} | ±10% |
| No colour | - | | ±20% |

Example Brown Green Red Gold - $1.5 \text{ k}\Omega \pm 5\%$

Brown Green Orange Gold - $15 \text{ k}\Omega \pm 5\%$

Grey Red Orange Gold - $82 \text{ k}\Omega \pm 5\%$

Yellow Blue Brown Gold - $460 \text{ k}\Omega \pm 5\%$

Brown Black Orange Silver - $10 \text{ k}\Omega \pm 10\%$

Five Colour Band System.

In the five colour band system, the first three bands give the 1st, 2nd and third significant digits of the resistance value, the fourth band is the multiple and the fifth band indicated %tolerance.

Example: The value and tolerance of the resistor with colour code Red, Yellow, Black, Black, and Gold is $240 \Omega \pm 5\%$.

Active Components:-

They can amplify or process signals by themselves. They use an energy source. Important active components are:

Vacuum tubes, diodes, transistors etc

They can be used for rectification and non-rectification purposes. Diodes allow unidirectional flow of current.

Eg. BY126, BY 127, IN 4001

The different types of diodes are:

Power diode, Signal diode, Varacter diode, Tunnel diode, Zener diode, LED, photodiode, etc.

Specification: for diodes include voltage rating, peak inverse voltage, maximum current rating.

a) Power diode:-

It is a general purpose diode. It is used in rectifier to convert ac to dc. It is a unidirectional current device. It is also called crystal diode. It is used in high power applications.

Eg. BY 126, BY127, DR 25, IN 4001, to IN 4007, IN 5400, IN 5408, BY 399, DI604

b) Signal Diode: It is a general purpose diode. It is used in radio receiver in the audio section. A red or black ring is marked on its body to indicate the cathode. It is used in low voltage and power applications.

Eg. OA 79, IN 4148, AA113.

It is used as demodulation detector in radio receiver.

c) Zener diode:-

It is a breakdown diode. Its voltage rating is 2.4 – 200V. It is used as voltage regulator. The values of the zener voltage are usually marked on the zener diode.

Eg. 5V6 means 5-6V

In some cases the power ratings are also marked

Eg. 3Z12 means 3W, 12V

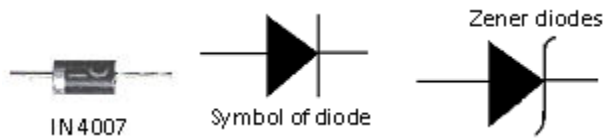

TRANSISTOR:

It is basically a Silicon or Germanium crystal containing three separate layers. It has three leads – emitter, base and collector. It is of two types – PNP and NPN transistors. They are used for purpose like amplification, oscillation etc.

Eg. For transistor – CK 100, AC 128

NPN transistor – SL 100, CL 100, BC 107, M9, BF 195D

(Used in radio receiver)

Transistor coding:

First letter denotes semiconductor material

A – Ge

B- Si

Second letter denotes application

C – low power, low frequency

D – high power, low frequency

F – low power, high frequency

L – High power, high frequency

Eg. AF 115 – low power high frequency general purpose transistor

BC 108 – General purpose. low power low frequency transistor

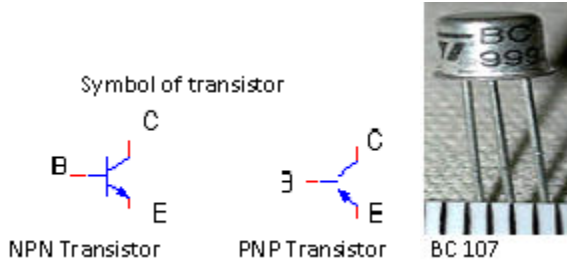

a) Power transistor:

It has three leads – base, emitter, and collector. Its body is the collector. Power transistor is used for high power applications. Due to high power, large heat will be released and to increase heat dissipation, collector area is made large.



b) Uni Junction Transistor (UJT):-

It has three leads – emitter, base B1, base B2. it is a single junction transistor. It has a negative resistance and it is used in oscillators, SCR etc. Eg. 2N2646, 2N2647, 2N5431.



UJT



FET

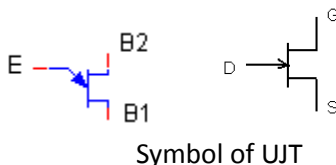

Symbol of UJT

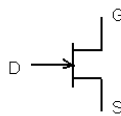

Symbol of FET

c) Field Effect Transistor (FET):-

It is a unipolar device. The magnitude of current is controlled by an electric field produced in it. It has four terminals source (S), drain (D), gate (G) and shield (S). FETs are of two types N – channel and P-channel. Its input impedance is very high and so it is ideal for the input stage for instrumentation applications.

Eg. BFW 10, BFW 61

d) Silicon Controlled Rectifier (SCR):-

It is a four layer device and it has three leads – anode, cathode and gate. It is a unidirectional device. It can convert ac to dc. It can control power coming to load. It is used in speed control of motors, high voltage rectification etc.

Eg. 2P4. SN 101. SN 202.

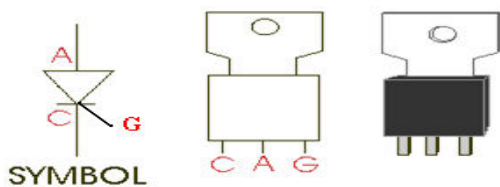

SCR

e)Triac:

It is a bilateral conduction device used in ac power control circuits. It has three terminals – MT_1 , MT_2 and gate. It is basically a diac with an added gate.
Eg. BT 136

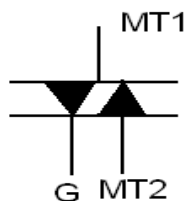

Triac

f)Integrated Circuit (IC):-

It is an elaborate electronic circuit which contains thousands of diodes, transistors, resistors or capacitors constructed on a single tiny piece of semiconductor crystal called a chip. They are classified as linear and digital according to the applications for which they are designed. They are available in flat and round shapes.

Crocodile clips



Crocodile clips

The 'standard' crocodile clip has no cover and a screw contact. However, miniature insulated crocodile clips are more suitable for many purposes including test leads. They have a solder contact and lugs which fold down to grip the cable's insulation, increasing the strength of the joint. Add and remove the cover by fully opening the clip, a piece of wood can be used to hold the jaws open.

Plugs

Plugs may have a screw or solder terminal to hold the cable. Check if you need to thread the cable through the cover before connecting it. Some plugs, such as those illustrated, are

'stackable' which means that they include a socket to accept another plug, allowing several plugs to be connected to the same point - a very useful feature for test leads.

Sockets

These are usually described as 'panel mounting' because they are designed to be fitted to a case. Most sockets have a solder contact but the picture shows other options. Fit the socket in the case before attaching the wire otherwise you will be unable to add the mounting nut.

Terminals

In addition to a socket these have provision for attaching a wire by threading it through a hole (or wrapping it around the post) and tightening the top nut by hand. They usually have a threaded stud to fit a solder tag inside the case.

Jack plugs and sockets

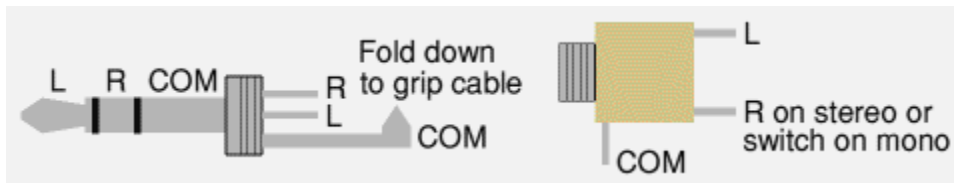

These are intended for audio signals so mono and stereo versions are available. The sizes are determined by the plug diameter: ¼" (6.3mm), 3.5mm and 2.5mm. The 2.5mm size is only available for mono.

Screened plugs have metal bodies connected to the COM contact. Most connections are soldered. Sockets are designed for PCB or chassis mounting.

¼" plug connections are similar to those for 3.5mm plug. ¼" socket connections are COM, R and L in that order from the mounting nut, ignore R for mono use. Most ¼" sockets have switches on all contacts which open as the plug is inserted so they can be used to isolate internal speakers for example.

Cables

- A **cable** is an assembly of one or more conductors (wires) with some flexibility.
- A **flex** is the proper name for the flexible cable fitted to mains electrical appliances.

Single core equipment wire

This is one solid wire with a plastic coating available in a wide variety of colours. It can be bent to shape but will break if repeatedly flexed. Use it for connections which will not be disturbed, for example links between points of a circuit board.



Stranded wire

This consists of many fine strands of wire covered by an outer plastic coating. It is flexible and can withstand repeated bending without breaking. Use it for connections which may be disturbed, for example wires outside cases to sensors and switches. A very flexible version ('extra-flex') is used for test leads.



Signal cable

Signal cable consists of several colour-coded cores of stranded wire housed within an outer plastic sheath. With a typical maximum current of 1A per core it is suitable for low voltage, low current signals where screening from electrical interference is not required. The picture shows 6-core cable, but 4-core and 8-core are also readily available.

Screened cable

The diagram shows the construction of screened cable. The central wire carries the signal and the screen is connected to 0V (common) to shield the signal from electrical interference. Screened cable is used for audio signals and dual versions are available for stereo.

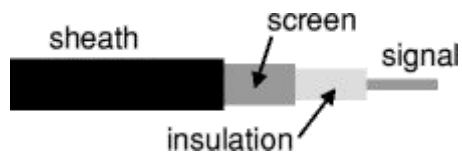

Construction of a screened cable

Co-axial cable



This type of screened cable is designed to carry high frequency signals such as those found in TV aerials and [oscilloscope](#) leads.

SWITCHES

Several terms are used to describe switch contacts:

- **Pole** - number of switch contact sets.
- **Throw** - number of conducting positions, single or double.
- **Way** - number of conducting positions, three or more.
- **Momentary** - switch returns to its normal position when released.
- **Open** - off position, contacts not conducting.
- **Closed** - on position, contacts conducting, there may be several on positions.





RESULT:-







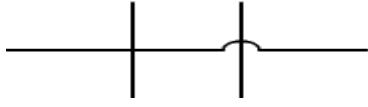
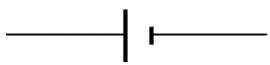
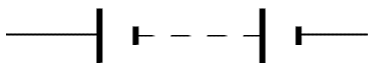

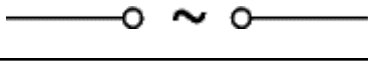
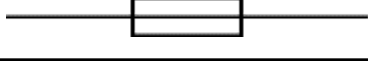
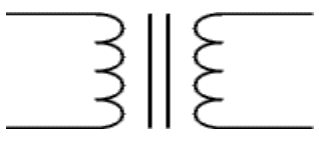
Electronics components are identified

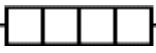

EXPT NO:2

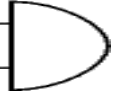
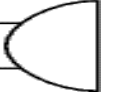

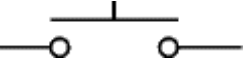
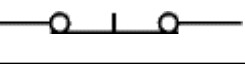
DATE:

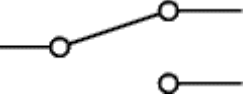
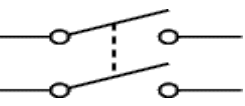
DRAWING OF ELECTRONIC CIRCUIT DIAGRAM USING BIS/IEEE SYMBOLS**SYMBOLS OF ELECTRONIC COMPONENTS**

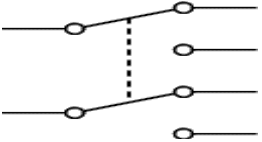
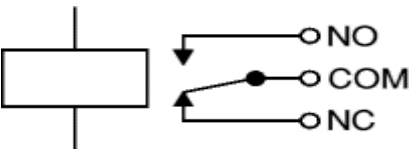

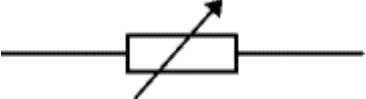
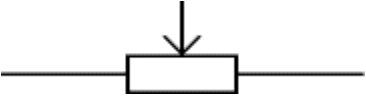
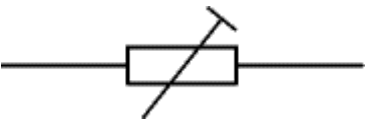
| Wires and connections | | |
|------------------------------|---|---|
| Component | Circuit Symbol | Function of Component |
| Wire |  | To pass current very easily from one part of a circuit to another. |
| Wires joined |  | A 'blob' should be drawn where wires are connected (joined), but it is sometimes omitted. Wires connected at 'crossroads' should be staggered slightly to form two T-junctions, as shown. |
| Wires not joined |  | In complex diagrams it is often necessary to draw wires crossing even though they are not connected. |
| Power Supplies | | |
| Cell |  | Supplies electrical energy. The larger terminal (on the left) is positive (+). |
| Battery |  | Supplies electrical energy. A battery is more than one cell. The larger terminal is positive (+). |
| DC supply |  | Supplies electrical energy. DC = Direct Current, always flowing in one direction. |
| AC supply |  | Supplies electrical energy. AC = Alternating Current, continually changing direction. |
| Fuse |  | A safety device which will 'blow' if the current flowing through it exceeds a specified value. |
| Transformer |  | Two coils of wire linked by an iron core. Transformers are used to step up (increase) and step down (decrease) AC voltages. Energy is transferred between the coils by the magnetic field in the core. There is no electrical connection between the coils. |

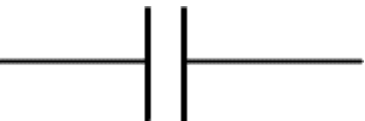

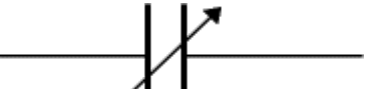
| | | |
|---|---|--|
| Earth (Ground) |  | A connection to earth. For many electronic circuits this is the 0V (zero volts) of the power supply, but for mains electricity and some radio circuits it really means the earth. It is also known as ground |
| Output Devices: Lamps, Heater, Motor, etc. | | |
| Lamp (lighting) |  | A transducer which converts electrical energy to light. |
| Lamp (indicator) |  | A transducer which converts electrical energy to light. This symbol is used for a lamp which is an indicator, for example a warning light on a car dashboard. |
| Heater |  | A transducer which converts electrical energy to heat. |
| Motor |  | A transducer which converts electrical energy to kinetic energy |
| Bell |  | A transducer which converts electrical energy to sound. |
| Buzzer |  | A transducer which converts electrical energy to sound. |
| Inductor (Coil, Solenoid) |  | A coil of wire which creates a magnetic field when current passes through it. It may have an iron core inside the coil. |
| Switches | | |
| Push Switch (push-to-make) |  | A push switch allows current to flow only when the button is pressed. This is the switch used to operate a doorbell. |
| Push-to-Break Switch |  | This type of push switch is normally closed (on), it is open (off) only when the button is pressed. |
| On-Off Switch (SPST) |  | SPST = Single Pole, Single Throw. An on-off switch allows current to flow only when it is in the closed (on) position. |
| 2-way Switch (SPDT) |  | SPDT = Single Pole, Double Throw. A 2-way changeover switch directs the flow of current to one of two routes according to its position. |
| Dual On-Off Switch (DPST) |  | DPST = Double Pole, Single Throw. A dual on-off switch which is often used to switch mains electricity because it can isolate both the live and neutral connections. |

| | | |
|--|---|--|
| <p>Reversing Switch (DPDT)</p> |  | <p>DPDT = Double Pole, Double Throw. This switch can be wired up as a reversing switch for a motor. Some DPDT switches have a central off position.</p> |
| <p>Relay</p> |  | <p>An electrically operated switch, for example a 9V battery circuit connected to the coil can switch a 230V AC mains circuit. NO = Normally Open, COM = Common, NC = Normally Closed.</p> |
| <p>Resistors</p> | | |
| <p>Resistor</p> |  | <p>A resistor restricts the flow of current, for example to limit the current passing through an LED. A resistor is used with a capacitor in a timing circuit. Some publications still use the old resistor symbol: </p> |
| <p>Variable Resistor (Rheostat)</p> |  | <p>This type of variable resistor with 2 contacts (a rheostat) is usually used to control current. Examples include: adjusting lamp brightness, adjusting motor speed, and adjusting the rate of flow of charge into a capacitor in a timing circuit.</p> |
| <p>Variable Resistor (Potentiometer)</p> |  | <p>This type of variable resistor with 3 contacts (a potentiometer) is usually used to control voltage. It can be used like this as a transducer converting position (angle of the control spindle) to an electrical signal.</p> |
| <p>Variable Resistor (Preset)</p> |  | <p>This type of variable resistor (a preset) is operated with a small screwdriver or similar tool. It is designed to be set when the circuit is made and then left without further adjustment. Presets are cheaper than normal variable resistors so they are often used in projects to reduce the cost.</p> |

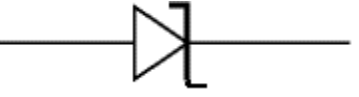
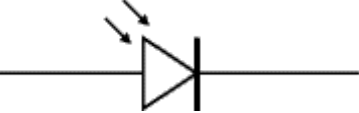

| | | |
|--|---|--|
| <p>Capacitors</p> | | |
| <p>Capacitor</p> |  | <p>A capacitor stores electric charge. A capacitor is used with a resistor in a timing circuit. It can also be used as a filter, to block DC signals but pass AC signals.</p> |
| <p>Capacitor polarised</p> |  | <p>A capacitor stores electric charge. This type must be connected the correct way round. A capacitor is used with a resistor in a timing circuit. It can also be used as a filter, to block DC signals but pass AC signals.</p> |
| <p>Variable Capacitor</p> |  | <p>A variable capacitor is used in a radio tuner.</p> |



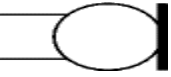
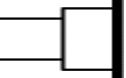
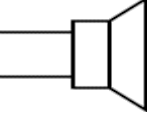

| | | |
|-----------------------------------|---|--|
| Trimmer Capacitor |  | <p>This type of variable capacitor (a trimmer) is operated with a small screwdriver or similar tool. It is designed to be set when the circuit is made and then left without further adjustment.</p> |
|-----------------------------------|---|--|

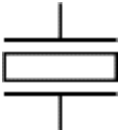
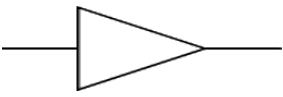

| Diodes | | |
|---|---|--|
| Diode |  | <p>A device which only allows current to flow in one direction.</p> |
| LED Light Emitting Diode |  | <p>A transducer which converts electrical energy to light.</p> |
| Zener Diode |  | <p>A special diode which is used to maintain a fixed voltage across its terminals.</p> |
| Photodiode |  | <p>A light-sensitive diode.</p> |

| Transistors | | |
|--------------------------------|---|--|
| Transistor NPN |  | <p>A transistor amplifies current. It can be used with other components to make an amplifier or switching circuit.</p> |
| Transistor PNP |  | <p>A transistor amplifies current. It can be used with other components to make an amplifier or switching circuit.</p> |
| Phototransistor |  | <p>A light-sensitive transistor.</p> |

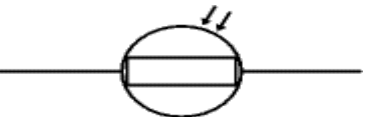

| Audio and Radio Devices | | |
|-----------------------------|---|--|
| Microphone |  | <p>A transducer which converts sound to electrical energy.</p> |
| Earphone |  | <p>A transducer which converts electrical energy to sound.</p> |
| Loudspeaker |  | <p>A transducer which converts electrical energy to sound.</p> |

| | | |
|----------------------------------|---|--|
| Piezo Transducer |  | A transducer which converts electrical energy to sound. |
| Amplifier (general symbol) |  | An amplifier circuit with one input. Really it is a block diagram symbol because it represents a circuit rather than just one component. |
| Aerial (Antenna) |  | A device which is designed to receive or transmit radio signals. It is also known as an antenna. |



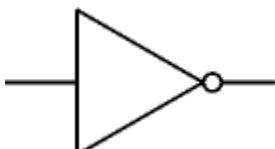

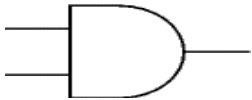

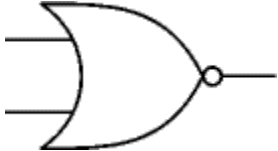
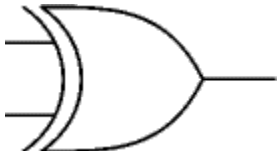
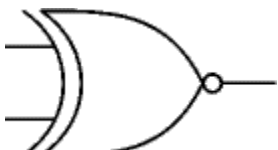







| Meters and Oscilloscope | | |
|------------------------------|---|---|
| Voltmeter |  | A voltmeter is used to measure voltage. The proper name for voltage is 'potential difference', but most people prefer to say voltage! |
| Ammeter |  | An ammeter is used to measure current. |
| Galvanometer |  | A galvanometer is a very sensitive meter which is used to measure tiny currents, usually 1mA or less. |
| Ohmmeter |  | An ohmmeter is used to measure resistance. Most multimeters have an ohmmeter setting. |
| Oscilloscope |  | An oscilloscope is used to display the shape of electrical signals and it can be used to measure their voltage and time period. |

| Sensors (input devices) | | |
|----------------------------|---|--|
| LDR |  | A transducer which converts brightness (light) to resistance (an electrical property). LDR = Light Dependent Resistor |
| Thermistor |  | A transducer which converts temperature (heat) to resistance (an electrical property). |

| Logic Gates | | |
|---------------------|---|---|
| Gate | Traditional Symbol | Function of Gate |
| NOT |  | A NOT gate can only have one input. The 'o' on the output means 'not'. The output of a NOT gate is the inverse (opposite) of its input, so the output is true when the input is false. A NOT gate is also called an inverter. |

| | | |
|---------------|--|---|
| <u>AND</u> |  | An AND gate can have two or more inputs. The output of an AND gate is true when all its inputs are true. |
| <u>NAND</u> |  | A NAND gate can have two or more inputs. The 'o' on the output means 'not' showing that it is a <u>Not AND</u> gate. The output of a NAND gate is true unless all its inputs are true. |
| <u>OR</u> |  | An OR gate can have two or more inputs. The output of an OR gate is true when at least one of its inputs is true. |
| <u>NOR</u> |  | A NOR gate can have two or more inputs. The 'o' on the output means 'not' showing that it is a <u>Not OR</u> gate. The output of a NOR gate is true when none of its inputs are true. |
| <u>EX-OR</u> |  | An EX-OR gate can only have two inputs. The output of an EX-OR gate is true when its inputs are different (one true, one false). |
| <u>EX-NOR</u> |  | An EX-NOR gate can only have two inputs. The 'o' on the output means 'not' showing that it is a <u>Not EX-OR</u> gate. The output of an EX-NOR gate is true when its inputs are the same (both true or both false). |

Types of Diodes

| Diode Name | Diode Symbol | Used for: | Special Characteristics |
|----------------------------|---|--|--|
| Rectifier Diode |  | Converting AC to DC | Can be had in very high current capacities, too slow for signal use. |
| Signal Diode |  | HF rectification, detection | Small t_r = few ns |
| Zener Diode |  | Voltage reference, regulation | Used in reverse breakdown |
| Light-emitting Diode [LED] |  | Indication, 7-segment displays | V_F 's vary with color |
| Photodiode |  | Light detection, mech. electrical conversion; solar cell | Reverse current is increased by light; in FWD direction=solar cell |
| Optocoupler |  | Electrical isolation | LED and photodiode in an opaque package |
| Schottky Diode |  | VHF rectification, detecting small signals | No stored charges, >300 MHz, 0.25V V_F [metal jn] |
| Varactor Diode |  | Tuning radio and TV receivers | Fairly linear C with V_R |
| Varistor |  | AC line spike protection | 2 back-back zeners |
| Current Regulator |  | Constant current source | |
| Step-recovery Diode |  | "snap" diode generates harmonics, f multipliers | Exploits reverse-current phenomenon |
| Back Diode |  | Very small signal rectification | V_R smaller than V_F |
| Tunnel Diode |  | High frequency oscillators | Part of forward char. has negative resistance |
| Laser Diode |  | Reading, writing CD, DVD etc. | |
| PIN Diode | | RF switching diode | |

EXPT NO :3

DATE:

FAMILIARIZATION /APPLICATION OF TESTING INSTRUMENTS AND COMMONLY USED TOOLS**AIM**

To familiarize with cathode ray oscilloscope and to study its function

Componentes and equipments required

CRO, function generator, capacitors and resistors

THEORY

CRO is an instrument which gives the visual representation of electric signals. It is one of the very versatile tools used for the research and study of electronics circuits and systems. It displays the signals on the screen in X and Y axes which is used in conventional graph construction. x-axis represents the time and y-axis represents the amplitude of the signal. Oscilloscopes are capable of displaying voltage variations which take place over a period of microseconds and nanoseconds.

Cathode ray tube is the heart of a CRO. It is a vacuum tube which generates a narrow electron beam which is made to fall on a fluorescent screen at one end of the tube. The electron beam is deflected horizontally and vertically by horizontal and vertical deflection plates. The controls and sockets in the front panel of a typical cathode ray oscilloscope are explained below.

VARIOUS CONTROLS OF CRO

1. **Power On:-** It is used to switch ON the instrument.
2. **Intensity control:-** It controls the trace intensity (brightness) from zero to maximum.
3. **Focus control:-** It controls the sharpness of the picture. The knob of the focus control regulates the positive potential of the focusing anode.
4. **Horizontal position control (X position):-** It controls the horizontal shifting of the trace.
5. **Vertical position control (Y Position):-** Controls the vertical shifting of the trace.
6. **VOLT/DIV:** It is used for displaying the waveforms in suitable vertical size. Amplitude of the signal can be determined by multiplying the number of divisions on the Y – Axis with the selected volt/div control.
7. **TIME/DIV:** It is used for displaying the waveforms in suitable horizontal size. Time period of the signal can be determined by multiplying the number of divisions for one cycle on the X – Axis with the selected time/div control.
8. **AC-GND-DC:** It selects the method of coupling of input signal. In ac, the direct coupling component of the input signal is blocked. In dc, all the components of input signals are passed to the vertical input amplifier of the oscilloscope. In gnd, input circuit is grounded.

9. **VARIABLE/LEVEL:** The control can be adjusted to provide triggering at desired dc level on the waveform being displayed.
10. **SLOPE (LEVEL):** this determines whether the trigger circuit responds on the positive going or negative going of the trigger signals.
11. **CAL:** It is the calibration signal output. It typically provides a 1KHz square waveform.
12. **CH1/CH2:** This switch selects the trigger signal in INT mode derived from either CH1/CH2 inputs.
13. **DUAL:** In this mode, CRO act as a dual trace oscilloscope.
14. **ADD:** When this switch is pressed, signals of CH1 and CH2 are added together.
15. **TV:** The display triggers from low frequency components of TV signal.
16. **LINE:** The display triggers from 50 Hz power line frequency
17. **INT/EXT:** This switch selects internal or external trigger signal.
18. **AUTO/NORM:** In auto mode, tracks give display in the absence of any input signal. In normal mode, tracks give display only when input signal is present.
19. **X10 MAG:** It expands the length of time base

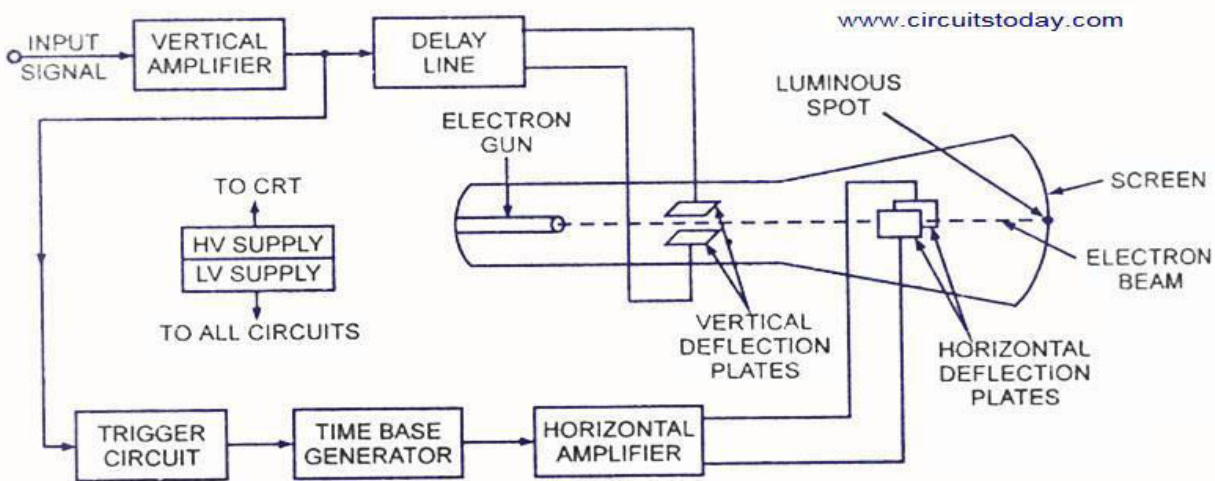

Block Diagram of a General Purpose CRO

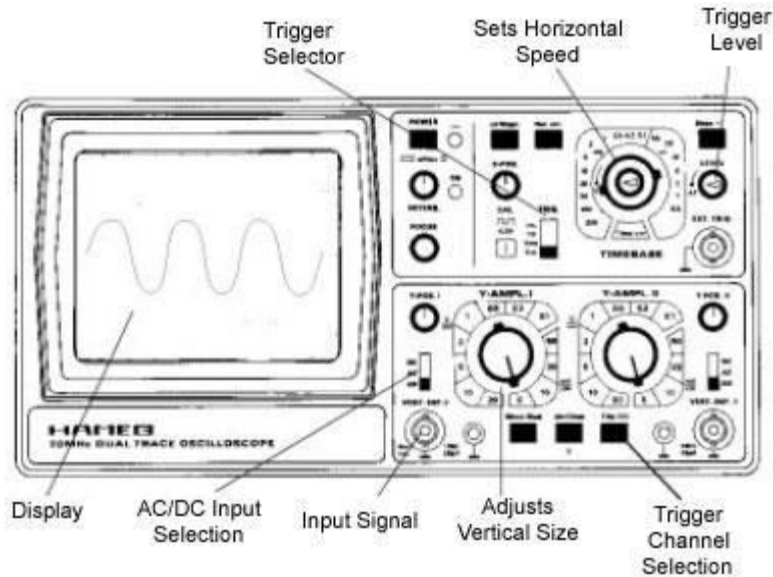

Figure : Front panel of CRO

APPLICATIONS OF CRO

- (1) Examination of wave forms
- (2) Voltage measurement
- (3) Frequency measurement

Voltage measurement:-

1. Switch ON the CRO and obtain a sharply defined trace of a horizontal line by adjusting INTENS and FOCUS knobs.
2. Adjust the Y-position of the knob so as to make the trace coincide with the centre line on the screen by keeping the AC-DC switch in GND position.
3. Apply the unknown voltage to the CRO using CRO probes. (CRO probe is a coaxial cord with a BNC [British Naval Connector] clip at one end and two crocodile clips at the other end).
4. Count the number of the vertical divisions occupied (peak to peak) by the wave and also note the VOLT/DIV switch position.
Peak to peak voltage = (Number of vertical divisions occupied) X (VOLT/DIV switch position)
5. Repeat the above steps for various settings of VOLT/DIV knob

Frequency measurement:-

1. Repeat steps 1 to 3 as said above.
2. Adjust the TIME/DIV knob so as to see two or three cycles of the waveform.
3. Count the number of horizontal divisions for completing one full cycle of the wave applied and note the TIME/DIV switch position.

Then ,

Time period T = (Number of divisions for completing one cycle) X (TIME/DIV switch

Frequency $f = 1/\text{Time Period}$ Unit = Hz

RESULT:-Familiarized with CRO and its knobs. Also studied how to measure amplitude and frequency of signals

FAMILARISATION OF MULTIMETERS

AIM:-To familiarize the uses of analog and digital multimeter by measuring different electrical quantities like resistance, voltage and current.

Analog Multimeter

A multimeter is an electronic instrument used for measuring voltage, current and resistance. The working principle of the analog multimeter is that when a current passes through the coil assembly of a multimeter, the coil deflects. A pointer is attached to the coil which moves on a scale. The angle of deflection is proportional to the current passing through the coil. The associated circuits in the multimeter provide necessary current limiting for the coil in the meter.

Digital multimeters

Digital meters give an output in numbers, usually on a liquid crystal display. The central knob has lots of positions and you must choose which one is appropriate for the measurement you want to make. If the meter is switched to 20 V DC, for example, then 20 V is the maximum voltage which can be measured. This is sometimes called 20 V **fsd**, where fsd is short for **full scale deflection**.

Precautions to be taken at the time of different measurements using multimeter

1. Before taking the measurements, see that the pointer is at zero. If not, set it to zero by adjusting screw.
2. At the time of voltage measurement, the selector switch should be kept at proper voltage. Precaution should be taken that it is not at current or ohm range.
3. At the time of resistance measurement in any device, the device should be disconnected from power supply. It should also be seen that the resistor should be isolated from the circuit.
4. At the time of voltage or current measurement, the device should be kept ON. Care should be taken from shock and other hazards.
5. If the range of the quantity to be measured is not known, then before taking measurements, the selector switch should be kept at maximum range and then a rough idea can be held to have the appropriate range.
6. Zero ohm adjustment should be made before making resistance measurements.
7. For current measurements, meter should be connected in series while for resistance and voltage measurements, it should be connected in parallel.
8. While making measurements with high voltage, the finger should be kept at the insulated probe only, otherwise, it may give shock.
9. The probe connection with the meter should be very tight.

11. The dry cells used inside the meter for ohm range should be checked up time to time and they should be replaced as soon as they become weak.
12. DC measurement should be made by connecting the meter with proper polarities.
13. In the case of analog multimeters, the terminal marked negative on the meter is actually connected to the positive terminal of the battery in side.

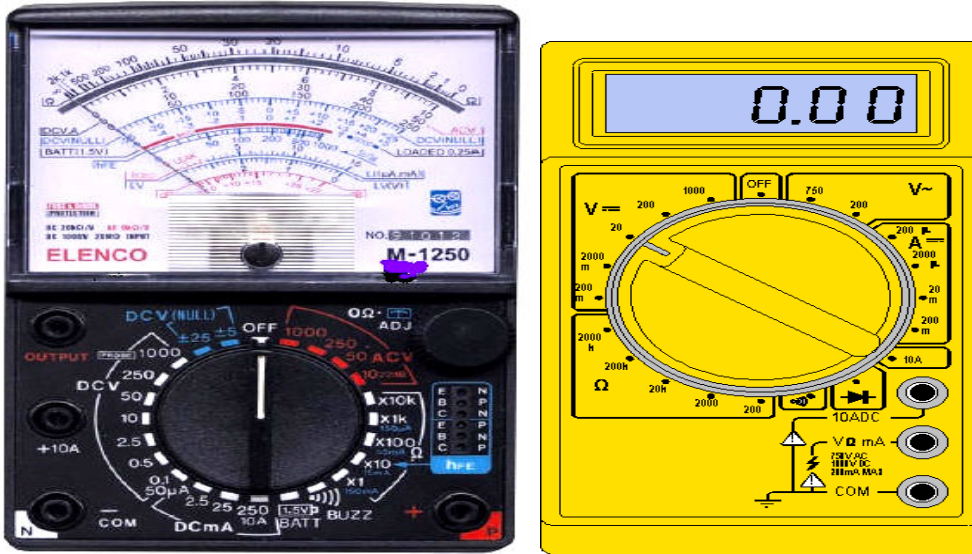

Figure Analog and digital multimeters

PROCEDURE:-

RESISTANCE MEASUREMENT:-

1. Select the ohm range.
2. Select the range (if the value is unknown, select the highest range and then reduce to lower range)
3. In the case of analog multimeter, short the probes of the multimeter and make zero adjustment. (separate zero adjustment must be done for each range)

Note:-

1. If one wants to measure the resistance of a resistor in a circuit, better is to remove the resistance from the circuit and take the measurement. Switch off the power before measuring the resistance of a circuit.
2. For high resistance measurement, ensure that the hands of the user is not touching the meter probes.

AC VOLTAGE MEASUREMENT:-

1. Select the ac voltage range.
2. If the value is unknown, select the highest range and then to reduce to lower range for getting more accurate value.

DC VOLTAGE MEASUREMENT:-

1. Select the dc voltage range.
2. If the value is unknown, select the highest range and then reduce to lower range for getting more accurate value.
3. For measuring dc voltages, consider the polarity of the meter. (In the case of analog multimeter consider red probe as negative and black probe as positive).

Note

To measure potential difference (voltage), the voltmeter is connected in parallel and to measure current, it is to be connected in series. Voltmeters must have a HIGH resistance

DC CURRENT MEASUREMENT:-

1. Select the dc current range.
2. If the value is unknown, select the highest range and then reduce to lower range for getting more accurate value.
3. For measuring dc currents, consider the polarity of the meter. (In the case of analog multimeter consider red probe as negative and black probe as positive).

RESULT:-Studied the working and the operation of multimeter.

FAMILARIZATION OF FUNCTION GENERATOR AND POWER SUPPLY

Aim

To familiarize with different types of DC sources and signal generators used in electronic laboratories and to study how to operate them

Components and Equipment Required

Single power supply, dual power supply , function generator.

DC Power Supplies

Almost all electronic components need a DC bias voltage. These are mainly categorized into fixed and variable power supplies .Some DC supplies provide only positive voltages while some other provide both positive and negative. DC supplies which provide positive and negative voltages are called dual power supplies .Certain integrated circuits and discrete circuits need dual power supplies .Operator can vary the dc voltage output from the variable DC sources using

Function generator

Many of the laboratory experiments need sine waves and square waves .Function generators provide various signals with a provision to vary the frequency and amplitude .In almost all the function generators three types of waveforms are available ;sine ,square, and triangular. The frequency range of the function generators is generally0 to 2 or 3 MHz. A knob named “offset” is provided to add positive or negative DC voltage to the generated signal .If the operator does not need any DC shift ,by turning this knob off, offset can be nullified and thus the signal can be made to swing exactly with respect to the zero reference. Attenuation knobs (-20 dB,-40 dB, or -60dB) are provided to obtain the signals in mV range.



Figure :Function generator and DC power supply

RESULT: Familiarized the dc sources and function generator

EXPT NO:4

TESTING OF ELECTRONIC COMPONENTS

AIM:- To study testing of ACTIVE and PASSIVE components

Components and Equipments Required:

Active and passive components, multimeter etc.

Theory:

Testing of Passive Components:

Note:-

While using the ohmic range of the analog multimeter, it is to be noted that ‘+ve’ voltage of the internal battery is available at the common point and ‘-ve’ voltage at the ohmic range selection. (In the case of digital multimeter red probe is ‘+ve’ and black probe is ‘-ve’). i.e, PN junction will be forward biased only when black probe is connected to the P region and red probe connected to the N region.

Electronic components may become faulty due to many reasons such as ageing, surrounding temperature, voltages and currents more than the rated value etc. Before constructing circuits, the components should be checked essentially.

Resistors: They can be tested by using an ohmmeter or a multimeter (with multimeter changed to desired range). Most common troubles in resistors is that it may be open or it shows very high resistance.

Based on the reading we can identify the following faults:

| Fault | Reading |
|---------------------|-----------------------|
| 1) Open | Infinitely high value |
| 2) Change of values | Incorrect resistance |

When taking the reading with the multimeter, care must be taken to have firm electrical connections between the meter leads and terminals of the resistor. Fingers must not touch resistor leads

Capacitors:

We can use the ohmmeter to check the following defects in capacitors
Short, open, partial short

All capacitor checks must be done on the highest resistance range of the ohmmeter. The

reading. The most common reason for an open capacitor is a broken internal connection. When checked, the open capacitors will cause a steady reading of excessive voltage. When a good capacitor is kept between the leads of an ohmmeter, the needle will swing from zero to infinity as capacitor will be determined by the size of the capacitor. After capacitors are charged, reading will hold steady.

Inductance Measurement:

Each inductor has a specific value of resistance. So testing of chokes can be done by measuring its dc resistance using multimeter. A zero resistance indicates shorted inductor. Infinite resistance indicates open inductance.

Another method for testing inductor is to measure inductance at a frequency specified by using a Q – meter.

Testing of Transformers:

Each winding of the transformer has a specified value of resistance. The value of resistance is proportional to the number of turns and gauge of wire used. The resistance check can be done by using an ohmmeter. Here infinite resistance shows open circuit and zero resistance in windings.

Testing of Active Components:

a) Testing of diode: (To test diode, lowest resistance range is selected):

Since diode is unidirectional device, its resistance will be low in forward biased state and will be very high in reverse bias condition. Therefore the condition of a diode can be tested by measuring its resistance in forward and reverse states by using a multimeter. The positive lead of the multimeter is pressed to the anode and negative to the cathode of the diode and value of resistance is noted. Now interchange the multimeter leads. The multimeter will show high resistance if the diode is good. An open diode will show high resistance in both cases and a shorter diode will show low resistance in both cases. Forward resistance is usually in the range of 1 to 25Ω.

b) Testing of Transistor:

A Transistor has three leads i.e., the emitter, collector and base.

i) NPN Transistor:

For checking a transistor, multimeter positive probe is connected to base and negative probe is connected to the emitter, it shows a low resistance. When connected in the reverse manner, it shows a high resistance. Now multimeter positive is connected to base and negative probe is connected to the collector, multimeter shows low resistance. Now reverse the connections. It will show high resistance.

Now connect the positive probe to the emitter and negative probe to the collector, it will show a high resistance. Now reverse the connections. It will show a high resistance.

ii) PNP transistor:

Multimeter positive probe is connected to base and emitter lead is connected to multimeter negative probe, it will show high resistance. Now reverse the connections it will show low resistance. Multimeter positive probe is connected to collector leads it shows high resistance. Multimeter positive is then connected to collector and negative to base, it shows low

Field Effect Transistor, FET

N-Channel FET

1. Connect the black lead of the meter to the gate terminal of FET. If the meter shows low resistance when red lead is connected to source and drain, we can say that forward characteristics is okay
2. Connect the red lead of the meter to gate. If the meter shows very high resistance when connecting the black lead to both source and drain, we can say that reverse characteristics is okay.
3. If any of the above condition is not satisfied, FET will be a bad one.

P-Channel FET

Testing of a P-channel FET is almost similar to that of N-Channel FET. All the above conditions of testing are to be carried out by interchanging red and black leads of the multimeter.

In the checking of MOSFET, care must be taken when handling it because of the small gate channel capacitance. Value of resistance between the different terminals are checked.

Silicon Controlled Rectifier:

It is a three terminal (three junction) semiconductor device which can be used as a controlled switch to perform various functions such as rectification, inversion etc. It is used to obtain controlled output from ac input.

1. Connect the black lead to anode of SCR and red lead to cathode. Meter reads high resistance.
2. Connect red lead to cathode and black lead to anode. Meter reads high resistance
3. Connect black lead of the meter to gate and red lead to cathode. Meter shows low resistance
4. Keeping the above condition undisturbed, check the resistance across anode and cathode using another multimeter connecting black lead to anode and red lead to cathode. Meter shows low resistance. Meter continues to show low resistance even when connection from gate is with drawn.
5. If any of the above conditions are not satisfied, SCR is said to be a bad one

Triac:

It is a bilateral conduction device used in ac power control circuits. It has three terminals – MT_1 , MT_2 and gate. It is basically a diac with an added gate.

Connect the positive ohmmeter lead to MT_2 and negative to MT_1 . The resistance reading will be very high. Then momentarily short a clip lead between MT_2 and gate. The ohmmeter will show low resistance. If the triac passes this test, its one half is checked. To check the other half of the triac, interchange the ohmmeter connection. Again resistance reading

direction. Ohmmeter reads low resistance and stay that way with gate open until one of the ohmmeter lead is removed.

Uni-Junction Transistor:

It is a three terminal semiconductor device having two doped region. In the three terminals it has one emitter and two bases (B1 and B2). This device has only one pn junction.

Checking a UJT:

When multimeter positive probe is connected to emitter and negative probe connected to B2, it shows low resistance. Positive probe is connected to emitter and negative to B1, it shows low resistance. When negative probe of multimeter is connected to emitter and positive to B1, it shows high resistance. Positive probe is connected to B1 and negative to B2, it shows same resistance.

Result:

Various active and passive components have been tested.

EXPT NO:5

DATE:

INTERCONNECTION METHODS AND SOLDERING PRACTICE

Aim:

To study about soldering practice.

Theory:

Soldering is a process by which two metals are joined using a tin containing alloy with low melting points as the filler material. Solders adhere strongly to the metal surface because of the metallurgical reaction that takes place with the tin in the solder.

Advantages of soldering iron:

Soldering guns are costly, but have the following advantages:

- a) They automatically turn off and consume less power
- b) Soldering gun can be used for intermittent application because it heats up almost instant at the press of a button.

Care of Soldering Iron:

The iron should be neat and clean. File the tip surface and then plug it into a current socket. The tip should shine like a mirror when ready for use. If tip is not clean and is dirty and black due to oxide coating or has holes in it, may cause cold soldering. It is not necessary to file or clean after every soldering job. The width of the tip should not be larger than a point to be soldered. The soldering iron and other tools should always be looked after carefully.

Solder:

It is the joining material that melts below 427°C. Soldered joints in electronic circuits will have established a strong electrical connection between component leads.

Preparation for soldering:

- a) The soldering iron should always be neat and clean.
- b) Any wire or surface which is to be soldered must be cleaned very carefully with the help of a knife.
- c) If the wire consists of 14 or more strands, twist them together so that all can be soldered. The plastic or cotton cover should be removed from the wire to about 1/4th of an inch. The covering should be carefully removed so that in cutting through the covering some strands of the wire itself are not cut.
- d) Connections should be made as short as possible and if convenient should be done in straight lines so as to trace out the event without much difficult.

Good joints:

When joining two components we must be sure that leads are clean. Twist the leads together. Apply a small amount of flux over it. The iron is usually kept under the connection to be made and the soldering is brought over the joint with the help of the other hand. The necessary amount of solder to cover the whole joint is melted.

Soldering Flux:

It helps in forming the solder joint. The soldering flux is placed on the metal surfaces to be soldered. It provides a wet surface for good soldering and it also removes the unwanted oxides from the surface of the metals to get perfect soldering. It helps to transfer heat to the surface being soldered.

- b) The leads of the components and surface to be soldered should be clean
- c) While soldering an endeavor must be made to see that connections are mechanically strong.
- d) Excessive flux should be removed and minimum quantity should be applied. Solder must also be used in less quantity and it should not make thick blobs anywhere.
- e) The iron should be kept under the connection and solder is brought over the joint. If the solder does not combine with a hot clean terminal, it indicates improper tinning or pasting of surface.

Dos' in soldering:

1. Use always an iron plated copper rod for soldering.
2. Clear the tip of the rod before soldering.
3. Use proper amount of soldering alloy and flux for soldering.
4. Be always careful with the heated soldering rod.
5. Use soldering rod only after it is heated to the proper amount of temperature.
6. Keep a damp cellulose sponge handy for tip cleaning as you solder.
7. Do soldering only in a ventilated room.
8. Use component holders and stabilizing stands during soldering.

Don'ts in soldering

1. As far as possible avoid soldering in a less ventilated room.
2. Don't keep soldering rod heated for along time.
3. Don't start soldering until the PC board artwork or any other component which has to be used is made clean.
4. Don't leave more time after the PC board has been etched, before soldering.
5. Don't start soldering before placing the soldering components in a stable position.
6. Don't reposition the soldering joint before it has formed a permanent bond.
7. Don't use conductors to hold the components to be soldered.

Use of desoldering wick

1. Apply wick and tip of soldering iron to the joint
2. As the solder melts, most of it will flow onto the wick.
3. Remove the wick first, then the soldering iron
4. Cut off and discard the end of the wick coated with solder.

Result:

A complete study is made on soldering.

EXPT NO:6

DATE:

PRINTED CIRCUIT BOARDS

Aim

To study the printed circuit board(pcb) fabrication technique.

Materials required

Copper clad sheet,paint or nail polish, drilling machine and ferric chloride solution.

PCB

PCB is used for soldering electronic components to form compact and rugged electronic circuits. A general purpose PCB is made of 2mm thick insulation board with a copper clad on one side .thickness of the copper clad is 30 to 40 μm .

Method

The following steps are involved in making a pcb.

- 1.Preparation Of The Lay-Out Of The Track.
- 2.Transferring The Lay-Out Of The Track.
- 3.Etching To Remove The Copper From The Copper Clad Wherever It Is Not Required.
- 4.Drilling Holes For Component Mounting.

Preparing lay-out

The track lay out of the electronic circuit must be drawn on a white paper.the lay out should be made in such a way that the paths are in easy routes. This enables the pcb to be more compact and economical.

Transferring the lay out to copper

The lay-out made on the white paper should be redrawn on the copper clad using paint or nail polish.

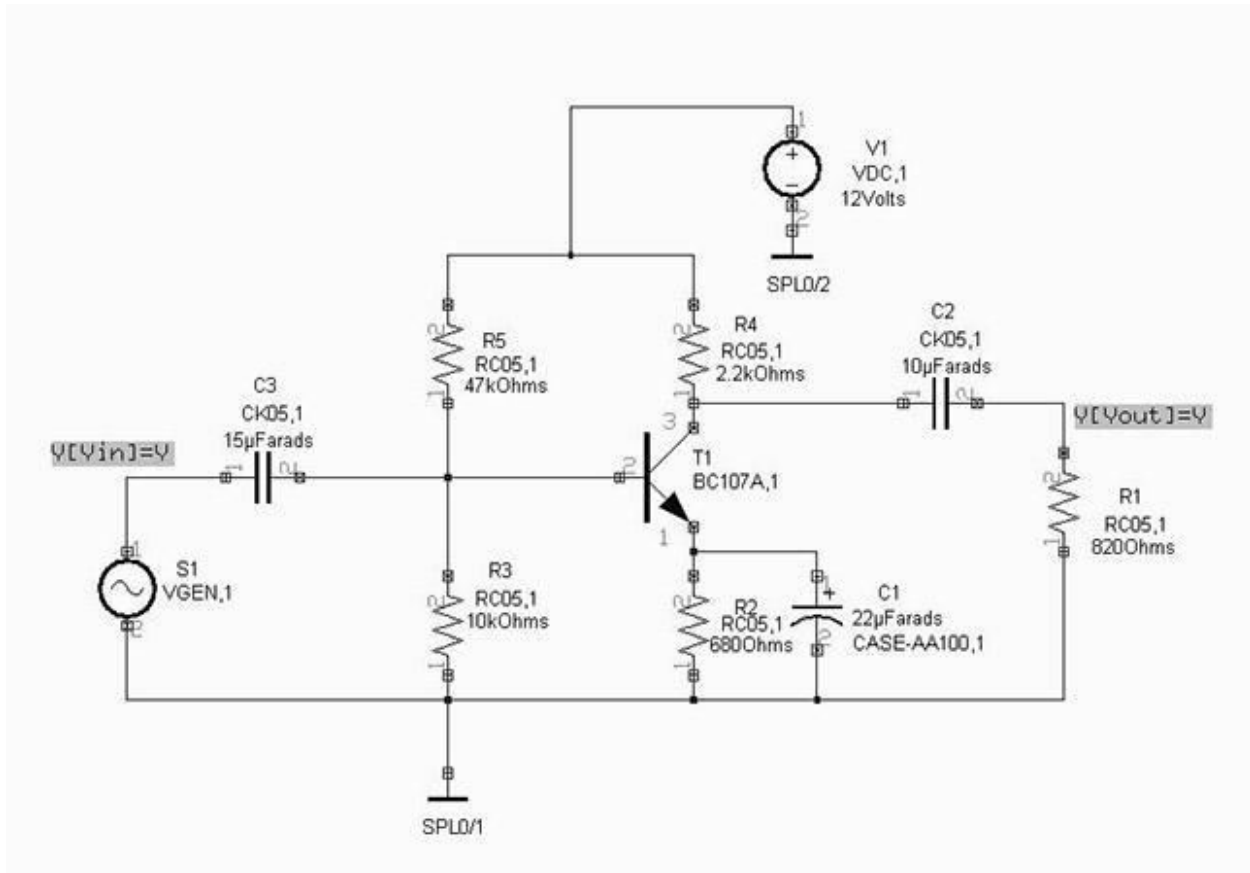

Figure : RC coupled amplifier

Etching

Ferric chloride solution is the popularly used etching solution. The ferric chloride powder is made in to a solution using water and kept in a plastic tray. Marked copper clad is immersed in this solution for two hours.

Due to the reaction ,solution will become weak and it is not recommended for another etching process. The copper in the unmarked area will be etced out. Take out the etched sheet from the tray and dry it in sunlight for an hour. Later remove the paint or nail varnish turpentine.

Drilling

The holes are made by a drilling machine for the component insertion.

ASSEMBLING OF ELECTRONIC SYSTEM /ON GENERAL PURPOSE PCB,TEST AND SHOW THE FUNCTIONING

SCHMITT TRIGGER CIRCUIT - USING IC555

AIM: To study the Schmitt trigger characteristics by using IC555 and compare theoretical and practical values of the Upper Threshold voltage, VUT and the Lower Threshold voltage, VLT.

APPARATUS:

Bread Board Function Generator CRO Probes Connecting wires 555 Timer, Resistors, Capacitors

THEORY:

555 timer can be used as Schmitt trigger. Here two internal comparators are tied together and externally biased at $VCC/2$ through R1 & R2. Since the upper comparator will trip at $(2/3) VCC$ and the lower comparator at $(1/3) VCC$ the bias provided by R1 & R2 is centered within these two thresholds. Thus a sine wave of sufficient amplitude ($> VCC/6 = 2/3 VCC - VCC/2$) to exceed the reference levels causes the internal flip-flop to alternately set and reset providing a square wave output.

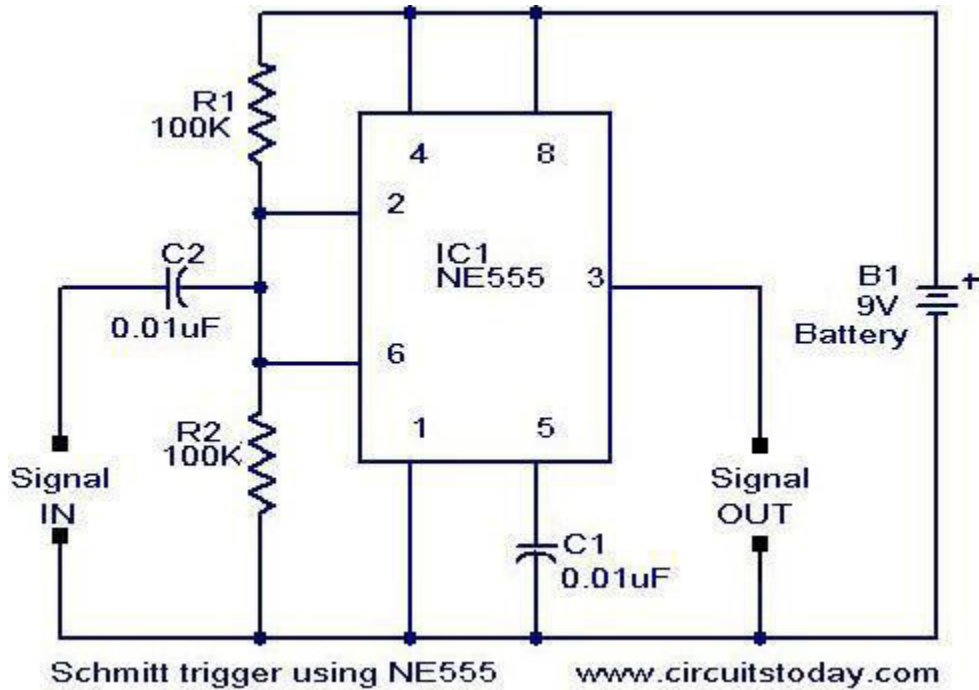

PROCEDURE:

1. Connect the components/equipment as shown in the circuit diagram.
2. Switch ON the power supply.
3. Apply the input sine wave using function generator.
4. Connect the channel-1 of CRO at the input terminals and Channel-2 at the output terminals.
5. Observe the output square waveform corresponding to input sinusoidal signal.
6. Overlap both the input and output waves and note down positions on sine wave where output changes its state. These positions denote the Upper threshold voltage and the Lower threshold voltage (see EXPECTED WAVEFORMS below).
7. Verify that these practical threshold voltages are almost same as the theoretical threshold voltages calculated using formulas given in the THEORY section above.
8. Sketch the waveforms by noting down the amplitude and the time period of the input V_i and the output V_o .

WAVE FORM

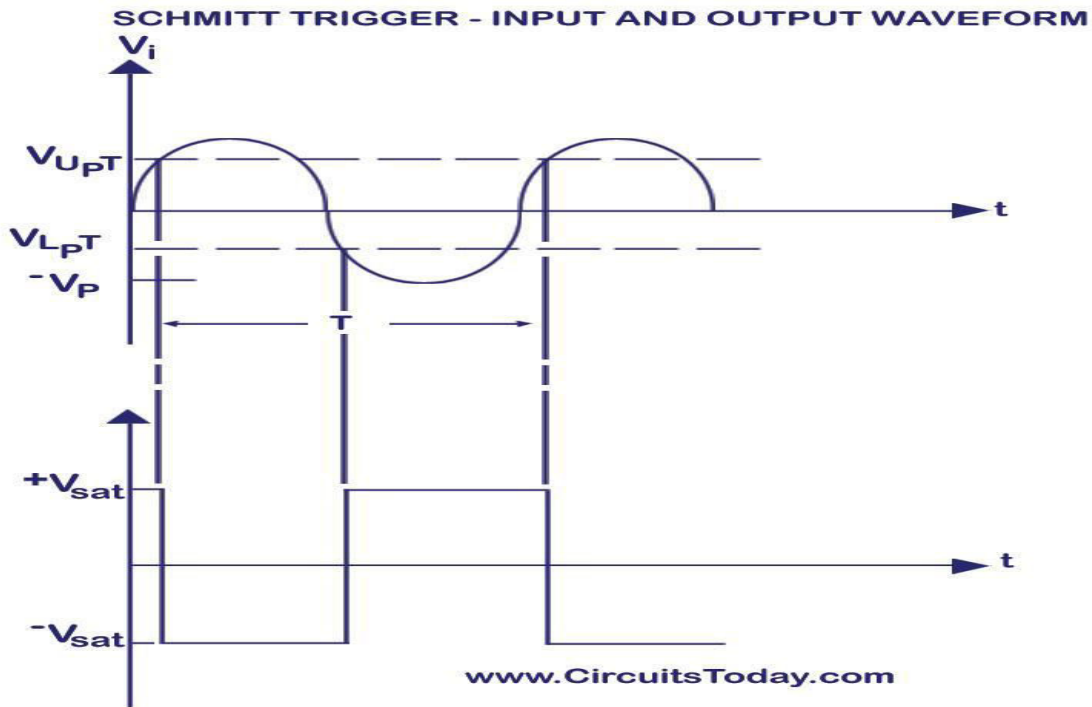

EXPT NO:8

RC COUPLED AMPLIFIER

Aim

To design and set up an RC-coupled CE amplifier using bipolar junction transistor and to plot its frequency response.

Components and equipments required

Transistor, dc source, capacitors, resistors, bread board, signal generator, multimeter and CRO.

Theory

RC-coupled CE amplifier is widely used in audio frequency applications in radio and TV receivers. It provides current, voltage and power gains. Base current controls the collector current of a common emitter amplifier. A small increase in base current results in a relatively large increase in collector current. Similarly, a small decrease in base current causes large decrease in collector current. The emitter-base junction must be forward biased and the collector base junction must be reverse biased for the proper functioning of an amplifier. In the circuit diagram, an NPN transistor is connected as a common emitter ac amplifier. R1 and R2 are employed for the voltage divider bias of the transistor. Voltage divider bias provides good stabilisation independent of the variations of β . The input signal V_{in} is coupled through CC1 to the base and output voltage is coupled from collector through the capacitor CC2. The input impedance of the amplifier is expressed as $Z_{in} = R1 \parallel R2 \parallel (1 + h_F E_{re})$ and output impedance as $Z_{out} = RC \parallel RL$ where r_e is the internal emitter resistance of the transistor given by the expression $r_e = 25 \text{ mV}/I_E$, where 25 mV is temperature equivalent voltage at room temperature

Selection of transistor Transistor is selected according to the frequency of operation, and power requirements. The $h_F E$ of the transistor is another aspect we should be careful about. Low frequency gain of a BJT amplifier is given by the expression. Voltage gain $A_v = -h_F E \frac{R_L}{R_i}$. In the worst case with $R_L = R_i$, $A_v = -h_F E$. $h_F E$ of any transistor will vary in large ranges. For example, the $h_F E$ of SL100 (a general purpose transistor) varies from 40 to 300. $h_F E$ of BC107 (an AF driver) varies from 100 to 500. Therefore a transistor must be selected such that its minimum guaranteed $h_F E$ is greater than or equal to A_v required.

Selection of supply voltage VCC For a distortionless output from an audio amplifier, the operating point must be kept at the middle of the load line selecting $V_{CEQ} = 50\% V_{CC} (= 0.5V_{CC})$. This means that the output voltage swing in either positive or negative direction is half of VCC. However, VCC is selected 20% more than the required voltage swing. For example, if the required output swing is 10 V, VCC is selected 12 V.

Selection of collector current I_C The nominal value of I_C can be selected from 14 Electronics Lab Manual Volume 1 the data sheet. Usually it will be given corresponding to $h_F E$ bias. It is the bias current at which $h_F E$ is measured. For BC107 it is 2 mA, for SL100 it is 150 mA, and for power transistor 2N3055 it is 4 A.

Design of emitter resistor R_E Current series feedback is used in this circuit using R_E . It stabilizes the operating point against temperature variation. Voltage across R_E must be as high as possible. But, higher drop across R_E will reduce the output voltage swing. So, as a rule of thumb, 10% of V_{CC} is fixed across R_E . $R_E = V_{RE} / I_E = V_{RE} / I_C$ since $I_E \approx I_C$, $R_E = 0.1 V_{CC} / I_C$

Design of RC Value of R_C can be obtained from the relation $R_C = 0.4V_{CC} / I_C$ since remaining 40% of V_{CC} is dropped across R_C .

Design of potential divider R_1 and R_2 Value of I_B is obtained by using the expression $I_B = I_C / h_F E_{min}$. At least $10I_B$ should be allowed to flow through R_1 and R_2 for the better stability of bias voltages. If the current through R_1 and R_2 is near to I_B , slight variation in I_B will affect the voltage across R_1 and R_2 . In other words, the base current will load the voltage divider. When I_B gets branched into the base of transistor, $9I_B$ flows through R_2 . Values of R_1 and R_2 can be calculated from the dc potentials created by the respective currents.

Design of bypass capacitor C_E The purpose of the bypass capacitor is to bypass signal current to ground. To bypass the frequency of interest, reactance of the capacitor X_{CE} computed at that frequency should be much less than the emitter resistance. As a rule of thumb, it is taken $X_{CE} \leq R_E / 10$.

Design of coupling capacitor C_C The purpose of the coupling capacitor is to couple the ac signal to the input of the amplifier and block dc. It also determines the lowest frequency that to be amplified. Value of the coupling capacitor C_C is obtained such that its reactance X_C at the lowest frequency (say 100 Hz or so for an audio amplifier), should be less than the input impedance of the amplifier. That means X_C must be $\leq R_{in} / 10$. Here $R_{in} = R_1 \parallel R_2 \parallel (1 + h_F E_{re})$ where r_e is the internal emitter resistance of the transistor given by the expression $= 25 \text{ mV} / I_E$ at room temperature.

PROCEDURE

1. Test all the components using a multimeter. Set up the circuit and verify dc bias conditions. To check dc bias conditions, remove input signal and capacitors in the circuit.
2. Connect the capacitors in the circuit. Apply a 100 mV peak to peak sinusoidal signal from the function generator to the circuit input. Observe the input and output waveforms on the CRO screen simultaneously. Electronics Lab Manual Volume 1 15
3. Keep the input voltage constant at 100 mV, vary the frequency of the input signal from 0 to 1 MHz or highest frequency available in the generator. Measure the output amplitude corresponding to different frequencies and enter it in tabular column.

4. Plot the frequency response characteristics on a graph sheet with gain in dB on y-axis and log f on x-axis. Mark log f_L and log f_H corresponding to 3 dB points. (If a semi-log graph sheet is used instead of ordinary graph sheet, mark f along x-axis instead of logf).

5. Calculate the bandwidth of the amplifier using the expression $BW = f_H - f_L$. 6. Remove the emitter bypass capacitor CE from the circuit and repeat the steps 3 to 5 and observe that the bandwidth increases and gain decreases in the absence of CE.

CIRCUIT DIAGRAM

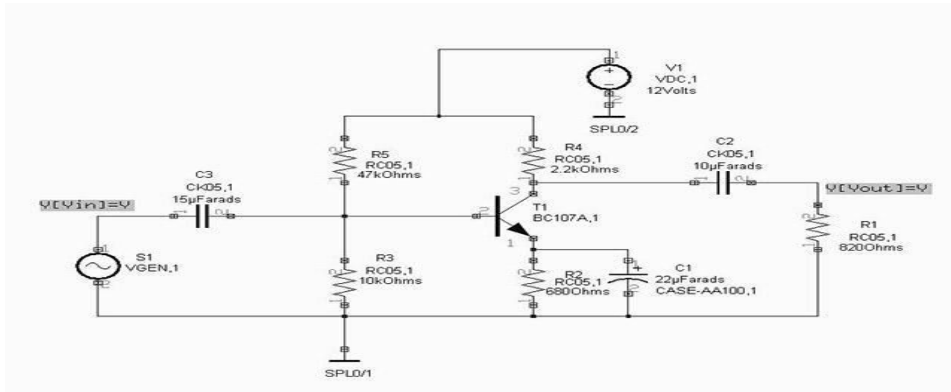

RC COUPLED AMPLIFIER

GRAPH

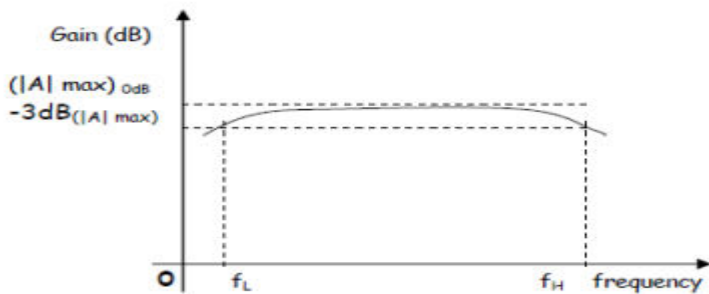

RESULT

With CE:

Mid-band gain of the amplifier =

Bandwidth of the amplifier = Hz

EXPT NO:9

DATE:.

FAMILIARIZATION OF SETTING UP OF A PA SYSTEM WITH DIFFERENT MICROPHONES ,LOUD SPEAKERS, MIXER

OBJECTIVE: - Study of different type of a Microphone their sensitivity & directivity.

THEORY: -

A microphone (called a mic or mike) is an acoustic-to-electric transducer or sensor that convertssound into an electrical signal. In 1876, Emile Berliner invented the first microphone used as a telephone voicetransmitter. Microphones are used in many applications such as telephones, tape recorders, karaoke systems,megaphones, in radioand television broadcasting and in computers for recording voice, speech recognition, VoIP, and for nonacousticpurposes such as ultrasonic checking or knock sensors. Most microphones today use electromagneticinduction (dynamic microphone), capacitance change (condenser microphone, pictured right), piezoelectricgeneration, or light modulation to produce an electrical voltage signal from mechanical vibration.

TYPES OF MICROPHONE :-

To further narrow a microphone's use for specific job applications, study thespecific characteristics of each type. These specific characteristics must be considered to best select amicrophone to perform a particular job. The five types of microphones presented here begin with the leasteffective and progress to the most efficient.

1) CARBON MICROPHONE:-

This microphone is activated by carbon granules, and is held in a container(a brass cup) attached to a metallic diaphragm. Sound waves striking the diaphragm cause a change in contactresistance among the granules. This change in contact causes a current from a battery, connected in serieswith the carbon button (brass cup), and the input of a transformer to vary in amplitude. The result is a currentwaveform similar to an acoustic waveform striking the diaphragm.After leaving the output of the transformer, the sound becomes amplified and reproduced. This principle ofoperation causes a high internal noise making the carbon microphone limited in its usage. All telephonereceivers use carbon microphones because telephone transmissions require only intelligibility and voice clarity.

- a. Frequency Response: 200-2000 Hz with much distortion present.
- b. Sensitivity: Low or poor, must be close to sound source.
- c. Impedance: Low.
- d. Internal Noise: Very high due to the friction of the carbon granules.
- e. Other characteristics: Inexpensive and rugged. Primarily used for communications (telephone).

2) **CRYSTAL MICROPHONE:-**

The crystal microphone uses one or more Rochelle salts placed in such a way that when a sound wave strikes them they bend or twist. This action produces an electrical current called the piezoelectric effect (pressure electricity).

- a. When exposing the crystal to a mechanical stress such as a sound wave striking a diaphragm (bimorph) or the crystal itself (sound cell), a minute current develops which is directly proportional to the mechanical pressure.
- b. The Bimorph and Sound Cell (trade names) make up the two most popular types of designs for crystal microphones.

Bimorph microphone

c. In the Bimorph, sound waves strike the surface of the diaphragm, creating pressure. The crystals consist of two slabs, separated by a thin piece of foil, which are connected to one side of the external circuit. The outer surfaces of the crystal slabs covered with foil connect to the other side of the external circuit.

- (1) Frequency Response: 80 - 6590 Hz
- (2) Directivity: Nondirectional
- (3) Impedance: High
- (4) Other Characteristics: Pressure-operated, inexpensive and small in size

3) **DYNAMIC MICROPHONES:-**

Known as the most ruggedly constructed of all broadcast microphones, the dynamic microphone may be found in sports, remote broadcasts, and studio recording situations. Because

“wind pickup” noise does not affect the microphone, it is used outdoors.

- (1) The dynamic microphone favors high frequencies over low. In the studio, this aids the speaker with a deeper bass voice to achieve a higher pitch. Due to its sensitivity to higher frequencies, it accentuates sibilance in a person's voice. (Some people produce a hissing sound while pronouncing s's and ch's. This hissing sound is sibilance.)
- (2) Dynamic Microphone Characteristics. This microphone operates on the moving coil generator principle (fig 2-27). It uses a diaphragm and coil which move the field of a permanent magnet. Sound waves striking the diaphragm cause the coil to be moved. This movement in a magnetic field generates an output voltage.

- (a) Frequency Response: 20 - 15,000 Hz which is nearly all of the audio spectrum.
- (b) Directivity: Omnidirectional
- (c) Sensitivity: Very high
- (d) Impedance: Low
- (e) Other Characteristics: Pressure-operated, rugged and sturdy.

3) **VELOCITY MICROPHONE:**

Because of its pickup element, manufacturers and studio broadcasters also call the

or in a studiorecording situation where it will have to be moved a great deal. Strong winds or rough handling could cause damage to the ribbon.

- (1) The velocity microphone favors low over high frequency sounds and consequently may be used to deepen a voice which is too high in pitch. The closer a performer is to this microphone the deeper his voice will sound.
- (2) When used in its normal mounted position, the velocity microphone possesses two live and two dead sides. Its pickup pattern is bidirectional. A performer may talk into either of the live sides of the microphone, or two performers may use both live sides alternately or simultaneously.

Principles of operation. A metallic ribbon is suspended between the poles of a permanent magnet which vibrates freely in a magnetic field. This ribbon, constructed of a thin aluminum strip, serves as the diaphragm.

Movement of this ribbon by a sound wave causes the magnetic lines of force to be cut crosswise, creating a

corresponding voltage between the two ends of the ribbon.

- (a) Frequency Response: 20 - 15,000 Hz
- (b) Directivity: Basically bidirectional
- (c) Sensitivity: Excellent
- (d) Impedance: Low
- (e) Other Characteristics: Since the ribbon is easily damaged, never use it outdoors

RESULT:- Study of microphone has been completed.

OBJECTIVE: - Study various types of Loudspeaker & their characteristic & application

THEORY:-

A loudspeaker (or "speaker") is an electroacoustic transducer that converts an electrical signal into sound. The speaker moves in accordance with the variations of an electrical signal and causes sound waves to propagate through a medium such as air or water. Loudspeakers (and other electroacoustic transducers) are the most variable elements in a modern audio system and are usually responsible for most distortion and audible differences when comparing sound systems. The term "loudspeaker" may refer to individual transducers (known as "drivers") or to complete speaker systems consisting of an enclosure including one or more drivers. To adequately reproduce a wide range of frequencies, most loudspeaker systems employ more than one driver, particularly for higher sound pressure level or maximum accuracy. Individual drivers are used to reproduce different frequency ranges. The drivers are named subwoofers (for very low frequencies); woofers (low frequencies); mid-range speakers (middle frequencies); tweeters (high frequencies); and sometimes supertweeters, optimized for the highest audible frequencies. The terms for different speaker drivers differ, depending on the application. In two-way systems there is no mid-range driver, so the task of reproducing the mid-range sounds falls upon the woofer and tweeter. Home stereos use the designation "tweeter" for the high frequency driver, while professional concert systems may designate them as "HF" or "highs". When multiple drivers are used in a system, a "filter network", called a crossover, separates the incoming signal into different frequency ranges and routes them to the appropriate driver. A loudspeaker system with n separate frequency bands is described as "n-way speakers": a two-way system will have a woofer and a tweeter; a three-way system employs a woofer, a mid-range, and a tweeter.

TYPES OF LOUDSPEAKER:

1) HORN LOUDSPEAKERS

Horn loudspeakers are the oldest form of loudspeaker system. The use of horns as voice-amplifying megaphones dates at least to the 17th century, and horns were used in mechanical gramophones as early as 1857. Horn loudspeakers use a shaped waveguide in front of or behind the driver to increase the directivity of the loudspeaker and to transform a small diameter, high pressure condition at the driver cone surface to a large diameter, low pressure condition at the mouth of the horn. This increases the sensitivity of the loudspeaker and focuses the sound over a narrower area. The size of the throat, mouth, the length of the horn, as well as the area expansion rate along it must be carefully chosen to match the drive to properly provide this transforming function over a range of frequencies (every horn performs poorly outside its acoustic limits, at both high and low frequencies). The length and cross-sectional mouth area required to create a bass or sub-bass horn require a horn many feet long. 'Folded' horns can reduce the total size, but compel designers to make compromises and accept increased complication such as cost and construction. Some horn designs not only fold the low frequency horn, but use the walls in a room corner as an extension of the horn mouth. In the late 1940s, horns whose mouths took up much of a room wall were not unknown amongst hi-fi fans. Room sized installations became much less acceptable when two or more were required.

ENCLOSURES:-



Most loudspeaker systems consist of drivers mounted in an enclosure, or cabinet. The role of the enclosure is to provide a place to physically mount the drivers, and to prevent sound waves emanating from the back of a driver from interfering destructively with those from the front; these typically cause cancellations (e.g., comb filtering) and significantly alter the level and quality of sound at low frequencies.

